

Art. 5800 АЛЮМІНІЄВИЙ ПНЕВМОПРИВОД - GNP **Art. 5800 PNEUMATIC ACTUATORS IN ALUMINIUM – GNP**

INSTRUCCIONES DE USO **OPERATING INSTRUCTIONS**

NOTA IMPORTANTE:

Antes de instalar y/o manipular estos actuadores neumáticos, **LEER ATENTAMENTE** estas instrucciones de empleo y **OBSERVAR** toda la información contenida en ellas. De no comprender alguna de las informaciones, rogamos **contactar con GENEBRE, S.A.**

IMPORTANT REMARK:

*Before setting up or handling these pneumatic actuators, **READ CAREFULLY** this user's guide and **OBSERVE** all the contained information. In case you don't understand some information, please **contact with GENEBRE, S.A.***

DATOS TÉCNICOS ATEX / ATEX TECHNICAL DATA

Expediente CE de custodia: LOM 08ATEX0037 / 01
(CE custody file):

Categoría aplicación ATEX: II 2 GD – c T5 / T100°C
(ATEX Classification):

Temperatura de uso: -20°C a/to +80°C
Temperature of use:



¡La responsabilidad del uso seguro de estos aparatos es del usuario de acuerdo a lo establecido en las presentes instrucciones de uso así como a la documentación técnica particular del aparato suministrado!



¡Safe use of this device is under responsibility of the user according to that established in these operating instructions as in the technical data sheet of this equipment!

INSTALACIÓN ATEX



Estos actuadores neumáticos son aptos para su uso en atmósferas explosivas:

Zonas 1 y 2 según IEC 60079-10-1, cuya Temperatura de auto ignición sea $\geq 105^{\circ}\text{C}$, sin límite de aplicación por subgrupo de gases, y en

Zonas 21 y 22 según IEC 60079-10-2, cuya Temperatura de auto ignición sea $\geq 150^{\circ}\text{C}$ en nube de polvo combustible y de $\geq 175^{\circ}\text{C}$ capas de polvo de cómo máximo 5 mm de espesor. Es aconsejable en los programas de mantenimiento limpiar la superficies del actuador para que no pueda existir capas superiores a estos 5 mm.

ATEX INSTALLATION



These pneumatic actuators are suitable to be set up in explosive atmospheres:

Zones 1 and 2 according to IEC 60079-10-1, whose self-ignition temperature is $\geq 105^{\circ}\text{C}$, with no restriction for the gas group, and in

Zones 21 and 22 according to IEC 60079-10-2, whose self-ignition temperature is $\geq 150^{\circ}\text{C}$ in combustible dust clouds, and $\geq 175^{\circ}\text{C}$ in layers of dust with a maximum thickness of 5 mm. It is recommended to include in the maintenance program a regular cleaning of the surface of the actuator to avoid thicker layers than 5 mm.

RECEPCIÓN DEL EQUIPO EN OBRA



¡El transporte y almacenaje de estos aparatos debe realizarse en su embalaje original!

INSPECCIÓN VISUAL

Comprobar que durante el transporte, descarga y emplazamiento, los aparatos no han sufrido daños.

VERIFICACIÓN MECÁNICA

Comprobar que todas las partes móviles de los aparatos, así como tornillos y demás elementos cumplen con su cometido.



¡De observar durante estas pautas de recepción, alguna anomalía, contactar urgentemente con GENE BRE con vistas a dirimir responsabilidades de las mismas y poner de nuevo los aparatos en correcto estado funcional!

RECEPTION OF THE EQUIPMENT ON SITE



¡Transport and storage of the equipment must be carried out in its original packaging!

VISUAL INSPECTION

Check if the equipment has been damaged during transport, uploading or location.

MECHANICAL VERIFICATION

Check that any mobile part of the equipment, as well as screws and other components, do their function.



¡In case you observe any anomaly during reception, keep in contact with GENE BRE in order to resolve responsibilities and put the equipment into operation again!

INSPECCIÓN, MANTENIMIENTO Y REPARACIÓN ATEX



¡Los reglamentos nacionales sobre mantenimiento, servicio, inspección y reparación de aparatos en emplazamientos con atmósferas explosivas, así como reglas generales de ingeniería deben de ser observados!

La realización de un mantenimiento defectuoso o incompleto puede conllevar al funcionamiento incorrecto del aparato (con el aumento de incidencias y por lo tanto de los costes de la no calidad).

Un buen mantenimiento permitirá reducir las incidencias del proceso (costes de la no calidad) y garantizará al mismo tiempo el cumplimiento de los requerimientos de seguridad y especificaciones del producto!



¡Los reglamentos nacionales deben ser observados!

Es responsabilidad del usuario establecer un plan de inspección y mantenimiento de estos aparatos con el fin de garantizar su uso seguro y debido.

Las inspecciones deben ser realizadas por personal cualificado para el tipo de aparatos y/o instalación que se requieren.

A efectos de guía se puede usar las prescripciones de la norma UNE-EN 60079-17, con el fin de establecer el plan de inspección en instalaciones en emplazamientos potencialmente explosivos.

Para la reparación de aparatos para atmósferas explosivas, es aconsejable seguir las requisiciones de la norma UNE-EN 60079-19.



¡Cuando las inspecciones sean del grado “Detallado” o en algunos casos de inspección por grado “Cercano”, los aparatos estarán totalmente fuera de servicio!



¡Usar únicamente partes/recambios originales o recomendados por GENEBRE, SA!

INSPECTION, MAINTENANCE AND ATEX REPAIR



¡National regulations about maintenance, service, inspection and repair of equipment in locations with explosive atmospheres, as well as general rules of engineering, must be observed!

A defective or incomplete maintenance can bear a malfunctioning of the equipment.

A good maintenance will allow reducing the incidences of the process (costs of the “no quality”) and will guarantee, at the same time, the fulfillment of the requirements of security and specifications of the product!

It is responsibility of the user to establish a plan of inspection and maintenance of these apparatuses with the purpose of guaranteeing its safe use.

The inspections must be made only by qualified personnel, in accordance with the type of equipment and installation required.

It is possible to follow the standard UNE-EN 60079-17 as a guide, in order to carry out a plan of inspection in facilities with potentially explosive atmospheres.

Regarding to the reparation of the equipment, it is advised to follow the requirements of the standard UNE-EN 60079-19.



¡When the inspections are classified as “Detailed” grade, or in some cases as “Near” grade, the equipment must be totally out of service!



¡Use only original spare parts or recommended by GENEBRE, SA!

CARACTERÍSTICAS

Cuerpo de aluminio extruido según ASTM 6005, con anodizado duro como protección a la corrosión interna y externa, con fino acabado interno del cilindro para obtener un bajo coeficiente de fricción, y posteriormente pintado externo con pintura de poliéster en polvo color azul.

El diseño compacto de piñón y cremallera doble permite un ensamblaje simétrico, un largo ciclo de vida, así como una rotación en sentido inverso (en este caso tan solo hay que realizar una simple inversión de los pistones).

Múltiples guías y rodamientos en cremallera y pistones que reducen la fricción, con largo ciclo de vida y diseño anti-expulsión del eje.

Diseño modular del cartucho con resorte precargado y revestido para mayor versatilidad, mayor seguridad y mayor resistencia a la corrosión.

Dientes completamente mecanizados en pistón y en piñón para una máxima eficacia y un mínimo contragolpe entre piñón y cremallera.

Fijadores en acero inoxidable para una mayor resistencia a la corrosión.

Conformidad completa con las últimas especificaciones: ISO5211, DIN 3337 y NAMUR confirmando una gran capacidad de adaptación y fácil montaje de electroválvulas, finales de carrera y otros accesorios.

Homologación ATEX según directiva 94/9/CE para atmósferas explosivas :
Categoría II 2 GD T5/T100°C (Zonas 1,2 / 21,22).

FEATURES

Extruded aluminium ASTM6005 body with internal surface having honed cylinder for longer life and low friction coefficient, and both internal and external corrosion protection treated with hard anodized and the external blue powder polyester painted.

Dual piston rack and pinion design for compact construction, symmetric mounting position, high-cycle life and fast operation, reverse rotation can be accomplished in the field by simply inverting the pistons.

Multiple bearings and guides on racks and pistons, low friction, high cycle life and prevent shaft blowout.

Modular preloaded spring cartridge design, with coated spring for simple versatile range, greater safety and corrosion resistance, longer cycle life.

Fully machined teeth on piston and pinion for accurate low backlash rack and pinion engagement, maximum efficiency.

Stainless steel fasteners for long term corrosion resistance.

Full conformance to the latest specifications: ISO5211, DIN 3337 and NAMUR or product interchange ability and easy mounting of solenoids, limit switches and other accessories.

ATEX certification according to 94/9/CE for explosive atmospheres:
Class II 2 GD T5/T100°C (Zonas 1,2 / 21,22).

DIMENSIONADO DOBLE EFECTO

El factor de seguridad sugerido para los actuadores de Doble Efecto bajo condiciones de trabajo normales es del 25% al 35%.

Ejemplo:

- El Par necesario para la válvula es de = 100 Nm
 - El Par considerando el factor de seguridad (100 + 30%) es de 130 Nm
 - Presión del aire de alimentación = 5 bar
- De acuerdo con la Tabla de Pares, nosotros debemos elegir el modelo más aproximado que es el **GNP 198**

DOUBLE ACTING SIZING

The suggested safety factor for Double Acting actuators under normal working conditions is 25%-35%.

Example:

- *The torque needed by valve=100Nm*
- *The torque considered safety factor (100 + 30%) = 130Nm*
- *Air Supply=5 bar*

*According to the above Torque Table, we can choose the minimum model is: **GNP 198***

DIMENSIONADO SIMPLE EFECTO

El factor de seguridad sugerido para los actuadores de Simple Efecto bajo condiciones de trabajo normales es del 25% al 35%.

Ejemplo:

- El Par necesario para la válvula = 100 Nm
 - El Par considerando el factor de seguridad (100 + 30%) es de 130 Nm
 - Presión del aire de alimentación = 5 bar
- De acuerdo con la Tabla de Pares que nos dan los actuadores de Simple Efecto, encontramos que los valores de pares del modelo **GNP 513 S4 (4+4)** son:
- Ejercido por aire a 0° = 291 Nm
Ejercido por aire a 90° = 221 Nm
Ejercido por muelles a 90° = 206 Nm
Ejercido por muelles a 0° = 137 Nm
- Todos los pares obtenidos son superiores al necesitado por la válvula

SPRING RETURN SIZING

The suggested safety factor for spring return actuator under normal working conditions is 25-35%

Example:

- *The torque needed by valve = 100 Nm*
- *The torque consider safety factor (100 + 30%) = 130 Nm*
- *Air Supply = 5 bar*

*According to the table of spring return actuators' output, we find output torque of **GNP 513 S4 (4+4)** are:*

*Air stroke 0°= 291 Nm
Air stroke 90°= 221 Nm
Spring stroke 90°=206 Nm
Spring stroke 0°=137 Nm*

All the output torque are larger than we needed.



CONDICIONES DE TRABAJO

- 1. Fluidos de accionamiento**
Aire seco o lubricado, gases no corrosivos.
- 2. Presión de suministro de aire**
Doble acción: 2 ÷ 8 Bar;
Simple acción: 2 ÷ 8 Bar
- 3. Temperatura de funcionamiento**
Standard: de -20°C +80°C
- 4. Recorrido del ajuste**
Tiene un rango de ajuste de $\pm 5^\circ$ para la rotación en 90°
- 5. Lubricación**
No necesita lubricante en condiciones normales de trabajo
- 6. Aplicación**
Cualquiera interior o exterior
- 7. Presión máxima**
La presión máxima de entrada debe ser de 8 bar

OPERATING CONDITIONS

- 1. Operating media**
Dry or lubricated air, non-corrosive gases.
- 2. Air supply pressure**
*Double acting: 2 ÷ 8 Bar;
Spring return: 2 ÷ 8 Bar*
- 3. Operating temperature**
Standard: -20°C+80°C
- 4. Travel adjustment**
Have adjustment range of $\pm 5^\circ$ for the rotation at 90°
- 5. Lubrication**
Under normal operating conditions, no lubricant is needed.
- 6. Application**
Either indoor or outdoor
- 7. Highest pressure**
The maximum input pressure is 8 Bar

DESPIECE DE RECAMBIOS

ASSEMBLE AND PARTS

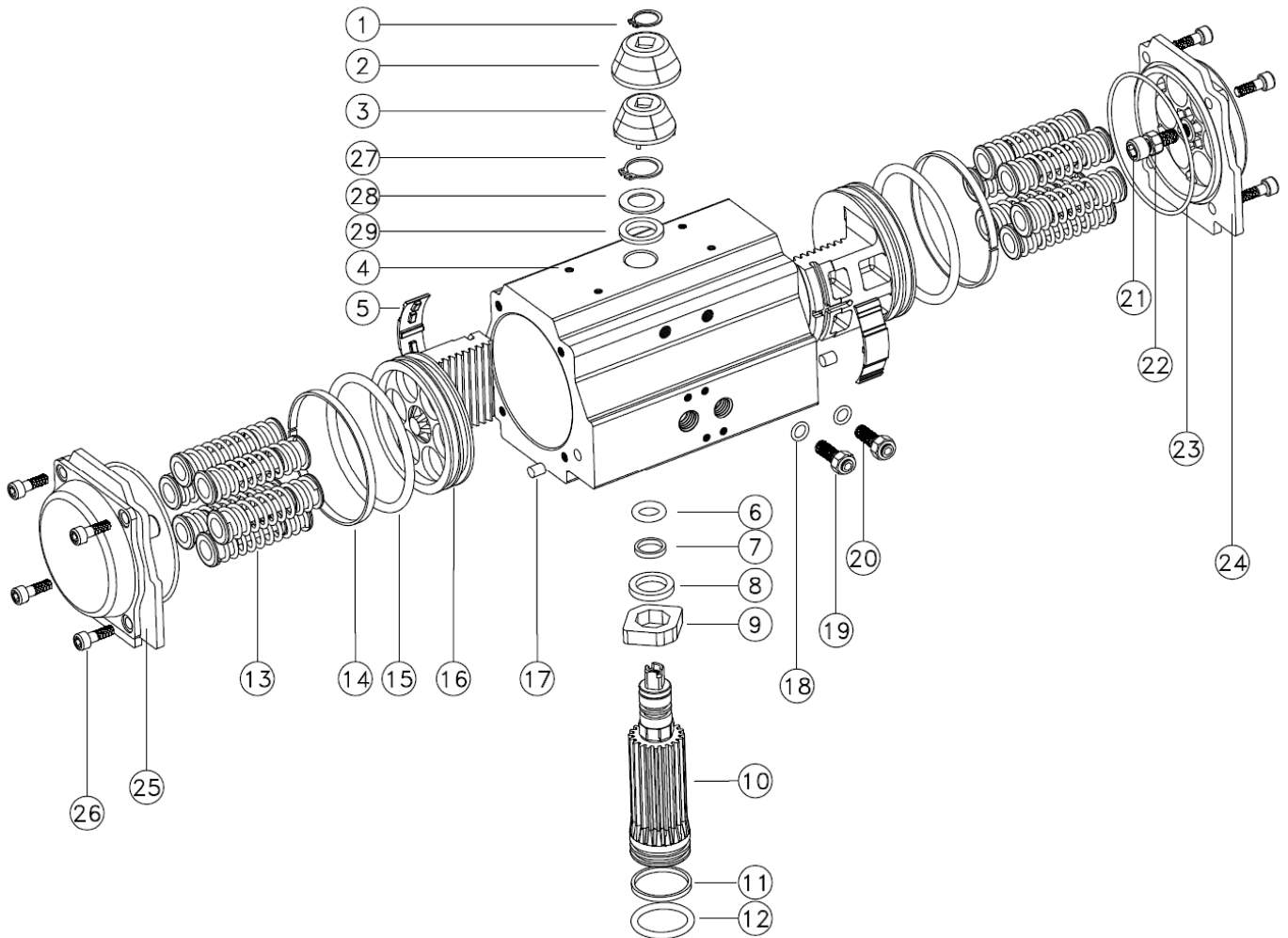

Nº	Denominación	Name	Qty	Material	Material	Protección
1	Anillo Seeger	<i>Spring clip</i>	1	AISI 304	<i>Stainless Steel</i>	
2	Carcasa indicador	<i>Housing indicator</i>	1	PC+ABS	<i>Plastic</i>	
3	Indicador	<i>Indicator</i>	1	PC+ABS	<i>Plastic</i>	
4	Cuerpo	<i>Body</i>	1	Al 6005-T5	<i>Extruded aluminium alloy</i>	<i>Anodized + painted</i>
5	Guía Pistón	<i>Guide piston</i>	2	Tecnopolímero	<i>POM</i>	
6	O-ring superior	<i>O-ring (pinion top)</i>	1	NBR	<i>NBR</i>	
7	Anillo superior	<i>Washer (pinion top)</i>	1	Tecnopolímero	<i>POM</i>	
8	Separador	<i>Bearing (pinion top)</i>	1	Tecnopolímero	<i>POM</i>	
9	Leva	<i>Cam</i>	1	Al. Acero	<i>Alloy steel</i>	
10	Piñón	<i>Pinion</i>	1	Al. Acero	<i>Alloy steel</i>	<i>Nickel plated</i>
11	Anillo inferior	<i>Bearing (pinion bottom)</i>	1	Tecnopolímero	<i>POM</i>	
12	O-ring inferior	<i>O-ring (pinion bottom)</i>	1	NBR	<i>NBR</i>	
13	Muelle	<i>Spring</i>	0-12	AISI 301	<i>Stainless Steel</i>	
14	Anillo pistón	<i>Ring (Piston)</i>	2	Tecnopolímero	<i>POM</i>	
15	O-ring pistón	<i>O-ring (Piston)</i>	2	NBR	<i>NBR</i>	
16	Pistón	<i>Piston</i>	2	Al. A380.1	<i>Cast aluminium</i>	<i>Anodized /galvanized</i>
17	Tapón	<i>Plug</i>	2	NBR	<i>NBR</i>	
18	O-ring	<i>O-ring</i>	2	NBR	<i>NBR</i>	
19	Tuerca	<i>Adjust Nut</i>	2	AISI 304	<i>Stainless Steel</i>	
20	Prisionero	<i>Adjust screw</i>	2	AISI 304	<i>Stainless Steel</i>	
21	Tornillo tope	<i>Stop screw</i>	2	AISI 304	<i>Stainless Steel</i>	
22	Tuerca tope	<i>Nut (stop screw)</i>	2	AISI 304	<i>Stainless Steel</i>	
23	O-ring tapa	<i>O-ring (End cap)</i>	2	NBR	<i>NBR</i>	
24	Tapa derecha	<i>End cap right</i>	2	Al. A380.1	<i>Cast aluminium</i>	<i>Anodized + painted</i>
25	Tapa izquierda	<i>End cap left</i>	2	Al. A380.1	<i>Cast aluminium</i>	<i>Anodized + painted</i>
26	Tornillo tapa	<i>Cap screw</i>	8	AISI 304	<i>Stainless Steel</i>	
27	Anillo Seeger	<i>Spring clip</i>	1	AISI 304	<i>Stainless Steel</i>	
28	Arandela	<i>Washer</i>	1	AISI 304	<i>Stainless Steel</i>	
29	Separador	<i>Ring</i>	1	Tecnopolímero	<i>POM</i>	

PIEZAS QUE COMPONEN EL KIT DE REPARACION / REPAIR KIT PARTS.

PO3MIPN

DIMENSIONS

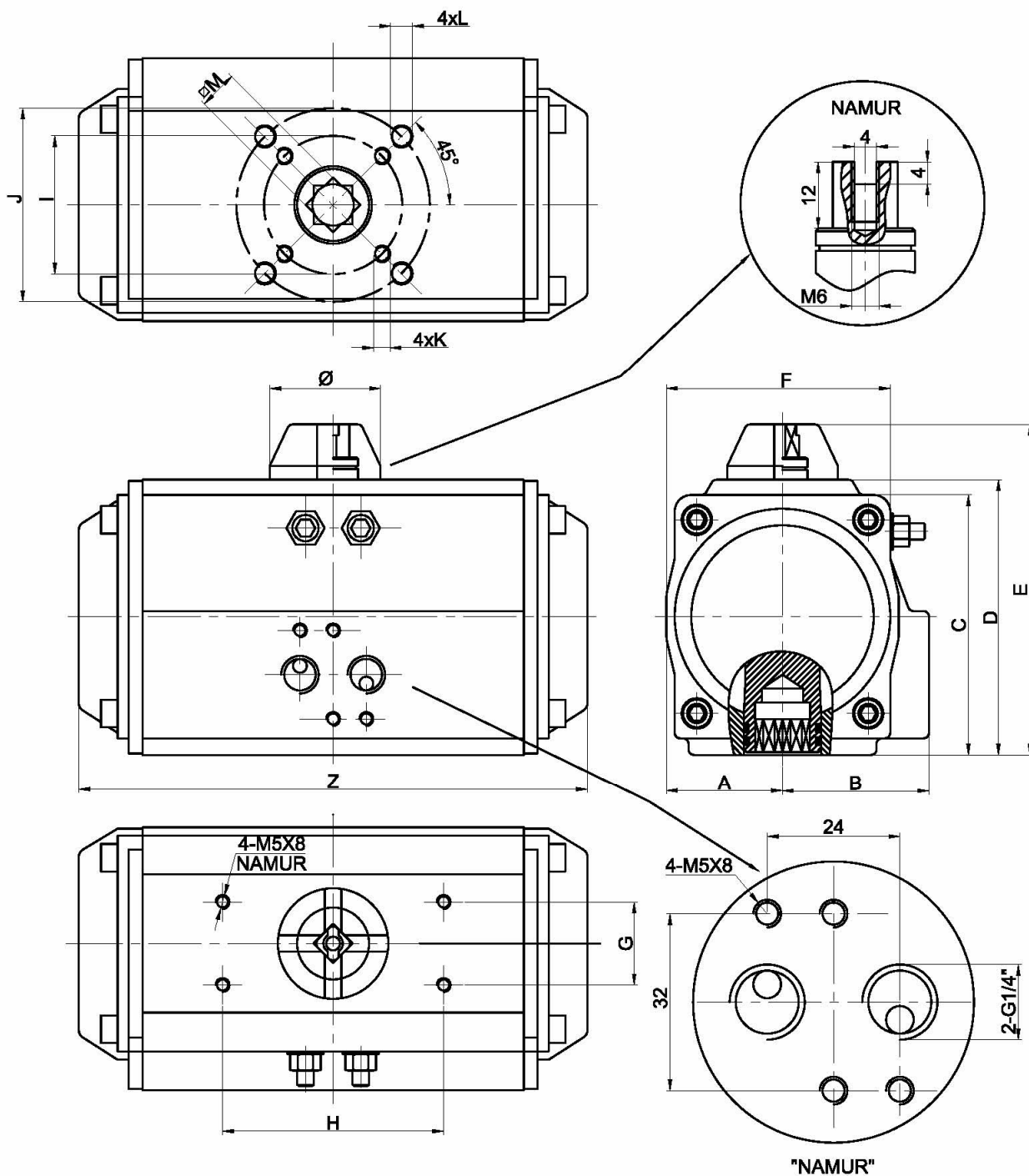

ТАБЛИЦЯ РОЗМІРІВ

DIMENSIONS TABLE

Model	A	B	C	D	E	F	G	H	I	J	K	L	M	N	Z	Ø	Air Connection
GNP14	28.5	36.5	60	-	90	52	30	80	(Φ36)*	(Φ42)*	M5	M5	11	14	122	Φ 55	NAMUR G1/4"
GNP24	30	41.5	65.5	72	102	65	30	80	(Φ36)*	(Φ42)*	M5	M5	11	14	147	Φ 55	NAMUR G1/4"
GNP44	36	47	81	87.5	117.5	72	30	80	(Φ42)*	(Φ50/Φ70)*	M5	M6/M8	14	18	168	Φ 55	NAMUR G1/4"
GNP60	42	53	94	99.5	129.5	81	30	80	Φ50	Φ70	M6	M8	14	18	184	Φ 55	NAMUR G1/4"
GNP94	46	57	98.5	108.7	138.7	92	30	80	Φ50	Φ70	M6	M8	17	21	204	Φ 55	NAMUR G1/4"
GNP135	50	58.5	111	116.8	146.8	98	30	80	Φ50	Φ70	M6	M8	17	21	262	Φ 55	NAMUR G1/4"
GNP198	57.5	64	122.5	133	163	109.5	30	80	Φ70	Φ102	M8	M10	22	26	268	Φ 55	NAMUR G1/4"
GNP300	67.5	74.5	145.5	155	185	127.5	30	80	Φ70	Φ102	M8	M10	22	26	296	Φ 80	NAMUR G1/4"
GNP513	75	77	160.7	171.5	201.5	137.5	30	80	Φ102	Φ125	M10	M12	27	31	390	Φ 80	NAMUR G1/4"
GNP800	87	87	184	197	227	158	30	80	Φ102	Φ125	M10	M12	27	31	454	Φ 80	NAMUR G1/4"
GNP1280	103	103	216	230	270	189	30	80/130	(Φ125)*	(Φ140)*	M12	M16	36	40	525	Φ 80	NAMUR G1/4"
GNP1600	113	113	235.5	255	295	210	30	80/130		Φ140		M16	36	40	532	Φ 91	NAMUR G1/4"
GNP2300	130	130	264	288	328	245	30	80/130		Φ140		M16	46	50	610	Φ 91	NAMUR G1/4"
GNP2500	147	147	299	326	366	273	30	80/130		Φ165		M20	46	50	722	Φ 91	NAMUR G1/4"

(*) debe elegirse una de las dos opciones / must choose one of two options

ВИТРАТА ПОВІТРЯ

AIR CONSUMPTION

Model	Volume opening	Volume closing	Model	Volume opening	Volume closing
GNP 14	0.08	0.11	GNP 300	1.60	1.40
GNP 24	0.12	0.16	GNP 513	2.5	2.2
GNP 44	0.21	0.23	GNP 800	3.7	3.2
GNP 60	0.30	0.34	GNP 1280	5.9	5.4
GNP 94	0.43	0.47	GNP 1600	7.5	7.5
GNP 135	0.64	0.73	GNP 2300	11.0	9.0
GNP 198	0.95	0.88	GNP 2500	17.0	14.0

El aire consumido depende de la presión, del volumen y del tiempo del ciclo y se calcula como sigue:

$I/min = \text{Volumen de aire (Volumen de aire Abriendo + Volumen de aire Cerrando)} \times [(Presión de aire alimentación (Kpa)+101.3) / 101.3] \times \text{Tiempo duración del ciclo (}/min)$

Air consumption depends on Air Supply. Air volume and Action cycle times, the calculating as follows

$I/min = \text{Air volume (Air volume Opening + Air volume closing)} \times [(Air Supply (Kpa)+101.3) / 101.3] \times \text{Action cycle times (}/min)$

КРУТНІ МОМЕНТИ ПРИВОДІВ ПОДВІЙНОЇ ДІЇ

Модель	Тиск подачі повітря/ Air supply pressure (Unit Bar)									
	2	2.5	3	4	4.5	5	5.5	6	7	8
GNP 14	4.8	6.0	7.2	9.5	10.7	11.9	13.1	14.3	16.7	19.1
GNP 24	8.0	10.0	12.0	16.0	18.0	20.0	21.9	23.9	27.9	31.9
GNP 44	14.6	18.2	21.9	29.2	32.8	36.5	40.1	43.8	51.1	58.4
GNP 60	20.1	25.1	30.1	40.1	45.1	50.2	55.2	60.2	70.2	80.3
GNP 94	31.4	39.2	47.0	62.7	70.5	78.4	86.2	94.1	109.7	125.4
GNP 135	45.1	56.4	67.7	90.3	101.6	112.9	124.1	135.4	158.0	180.6
GNP 198	66.1	82.7	99.2	132.2	148.8	165.3	181.8	198.4	231.4	264.5
GNP 300	100.3	125.4	150.5	200.6	225.7	250.8	275.9	301.0	351.1	401.3
GNP 513	171.0	213.8	256.5	342.0	384.8	427.5	470.3	513.0	598.5	684.0
GNP 800	266.0	332.5	399.0	532.0	598.5	665.0	731.5	798.0	931.0	1064.0
GNP 1280	425.6	532.0	638.4	851.2	957.6	1064.0	1170.4	1276.8	1489.6	1702.4
GNP 1600	532.0	665.0	798.0	1064.0	1197.0	1330.0	1463.0	1596.0	1862.0	2128.0
GNP 2300	769.5	961.9	1154.3	1539.0	1731.4	1923.8	2116.1	2308.5	2693.3	3078.0
GNP 2500	1169.6	1462.1	1754.5	2339.3	2631.7	2924.1	3216.5	3508.9	4093.7	4678.6

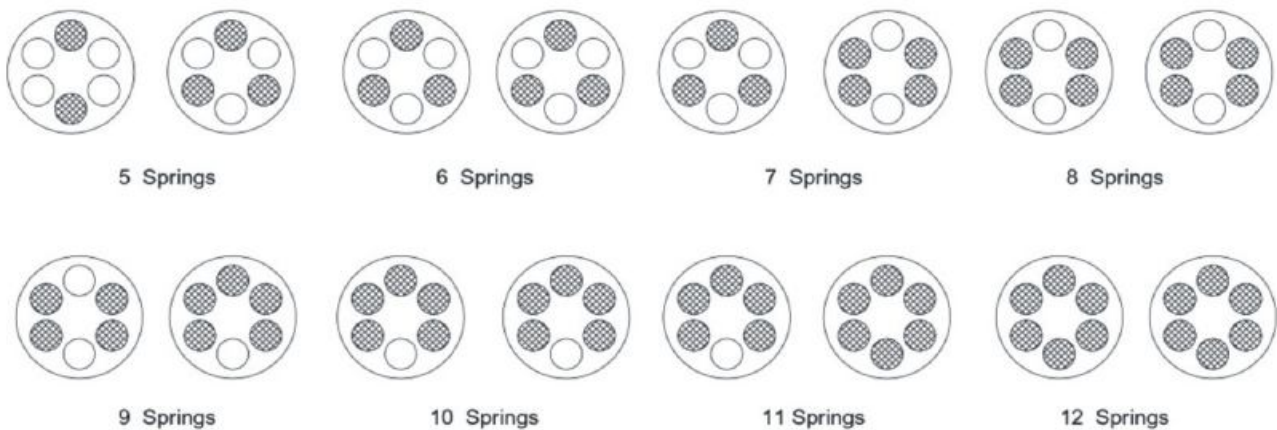

КРУТНІ МОМЕНТИ ПРУЖИННОГО ПРИВОДУ

TIPO/ TYPE	Cantidad de muelles /Spring Qty	ТИСК ПОВІТРЯ НА ВХІДІ В БАР/ AIR SUPPLY IN BAR														Spring output/ Obtenido por muelle		
		2,5		3		4		5		6		7		8		90°	0°	
		0°	90°	0°	90°	0°	90°	0°	90°	0°	90°	0°	90°	0°	90°			
GNP 24S	3 + 2	5.7	3.8	7.6	5.7												6.2	4.3
	3 + 3	4.9	2.5	6.9	4.5	10.9	8.5										7.4	5.0
	4 + 3	4.0	1.3	6.0	3.3	9.8	7.3	14.0	10.4								8.6	5.9
	4 + 4			5.2	2.0	9.2	6.0	13.2	9.1	17.2	14.1						9.9	6.7
	5 + 4			4.3	0.8	8.3	4.8	12.3	7.9	16.3	12.8	20.3	16.8				11.1	7.6
	5 + 5					7.4	3.6	11.5	6.7	15.5	11.6	19.5	15.6				12.4	8.5
	6 + 5					6.6	2.3	10.6	5.4	14.6	10.4	18.6	14.3	22.6	18.3		13.6	9.3
6 + 6							9.7	4.2	13.8	9.1	17.8	12.2	21.8	17.1		14.8	10.2	
GNP 44S	3 + 2	11.4	7.7	15.0	11.4	22.3	14.9										10.4	6.8
	3 + 3	10.1	5.7	13.6	9.3	20.9	16.6	28.3	23.9								12.5	8.2
	4 + 3	8.6	3.6	12.5	7.2	19.5	14.5	26.8	21.9								14.6	9.6
	4 + 4			10.9	5.1	18.2	12.4	25.5	19.8	32.8	27.0	40.1	34.3				16.7	10.9
	5 + 4					16.8	10.4	24.1	17.7	31.4	24.9	38.7	32.3				18.8	12.3
	5 + 5					1.4	8.2	22.8	15.6	30.0	22.8	37.3	30.1	44.7	37.4		20.9	13.7
	6 + 5							21.5	13.5	28.7	20.7	36.0	28.0	43.3	35.3		22.9	15.0
6 + 6							20.0	11.4	27.3	18.6	34.6	25.9	41.9	33.3		25.0	16.4	
GNP 60S	3 + 2	14.5	10.6	19.4	15.5	29.5	25.7										14.5	10.5
	3 + 3	12.4	7.6	17.3	12.6	27.4	22.7	37.5	32.8								17.4	12.7
	4 + 3	10.4	4.8	15.2	9.7	25.3	19.6	35.4	29.9								20.3	14.8
	4 + 4			13.1	6.8	23.1	16.9	33.3	27.0	43.2	37.0	53.3	47.0				23.2	16.9
	5 + 4					21.0	14.1	31.2	24.1	41.1	34.1	51.2	44.2				26.1	19.0
	5 + 5					19.0	11.1	28.8	21.2	39.0	31.2	49.1	41.2	59.1	51.2		29.0	21.1
	6 + 5							27.0	8.3	37.0	28.3	47.0	38.4	57.0	48.4		31.9	23.2
6 + 6							24.9	15.4	34.9	25.4	44.9	35.4	54.9	45.4		34.7	25.3	
GNP 94S	3 + 2	23.3	16.1	31.1	24.0	46.8	39.7										23.0	15.8
	3 + 3	20.1	11.5	28.0	19.3	43.7	35.1	59.4	50.7								27.6	19.0
	4 + 3	17.0	6.9	24.8	14.8	40.5	30.5	56.2	46.2								32.2	22.1
	4 + 4			21.7	10.1	37.4	25.8	53.1	41.5	68.8	57.2	84.5	72.9				36.8	25.3
	5 + 4					34.2	21.3	49.9	37.0	65.6	52.6	81.2	68.3				41.4	28.5
	5 + 5					31.0	16.6	46.7	32.3	62.4	48.0	78.1	63.7	93.8	79.3		46.0	31.6
	6 + 5							43.6	27.7	59.3	43.4	75.0	59.1	90.6	74.8		50.6	34.8
6 + 6							40.4	23.2	56.1	38.9	71.7	54.5	87.4	70.2		55.2	38.0	
GNP 135S	3 + 2	33.1	22.0	44.2	33.2	66.8	55.9										34.4	23.3
	3 + 3	28.4	15.2	39.6	26.4	62.2	49.0	84.4	71.6								41.2	28.0
	4 + 3	23.8	8.2	34.9	19.4	57.5	42.1	80.2	64.7								48.1	32.7
	4 + 4			31.3	12.6	52.9	35.2	75.5	57.9	98.1	80.5	120.7	103.0				55.0	37.3
	5 + 4					48.2	28.4	70.9	51.0	93.5	73.6	116.0	96.1				61.9	42.0
	5 + 5					43.6	21.5	66.2	44.1	88.8	66.7	111.3	89.2	134.0	111.8		68.7	46.7
	6 + 5							61.5	37.2	84.1	59.9	106.6	82.4	129.2	105.0		75.6	51.4
6 + 6							56.8	30.4	79.4	53.0	101.9	75.5	124.5	98.1		82.5	56.0	
GNP 198S	3 + 2	51.0	33.4	67.5	49.9	100.6	83.0										49.2	31.6
	3 + 3	44.7	23.5	61.1	40.0	94.2	73.2	127.3	106.2								59.1	38.0
	4 + 3	38.4	13.7	54.9	30.3	87.9	63.4	121.0	96.4								68.9	44.3
	4 + 4			48.5	20.4	81.6	53.5	114.7	86.5	147.7	119.6	180.8	152.7				78.7	50.6
	5 + 4					75.3	43.7	108.4	76.8	141.5	109.8	174.5	142.9				88.6	56.9
	5 + 5					68.9	33.4	102.0	66.5	136.1	99.6	168.2	132.6	201.2	165.7		98.4	63.3
	6 + 5							95.7	57.0	128.7	90.1	161.8	123.1	194.8	156.2		108.3	69.6
6 + 6							89.4	47.5	122.5	80.6	155.5	113.6	188.6	146.7		118.1	75.9	
GNP 300S	3 + 2	73	47	98	72	148	122										79	52
	3 + 3	63	31	88	56	138	107	188	157								94	63
	4 + 3	52	15	77	40	127	90	178	141								110	73
	4 + 4			67	25	117	75	167	125	217	176	268	226				125	84
	5 + 4					107	59	157	109	207	159	257	210				141	94
	5 + 5					96	44	146	94	196	144	247	194	297	245		157	105
	6 + 5							136	78	186	128	236	178	286	228		173	115
6 + 6							125	63	176	113	226	163	276	213		188	125	

TIPO/ TYPE	Cantidad de muelles /Spring Qty	ТИСК ПОВІТРЯ НА ВХІДІ В БАР/ AIR SUPPLY IN BAR														Spring output/ Obtenido por muelle		
		2,5		3		4		5		6		7		8		90°	0°	
		0°	90°	0°	90°	0°	90°	0°	90°	0°	90°	0°	90°	0°	90°			
GNP 513S	3 + 2	128	85	171	127	256	213										129	86
	3 + 3	111	59	154	102	239	187	325	273								155	103
	4 + 3	94	33	137	76	222	162	308	247								181	120
	4 + 4			120	50	205	136	291	221	376	307	462	392				206	137
	5 + 4					187	110	273	196	358	281	444	367				232	155
	5 + 5					170	84	256	169	341	255	427	340	512	426		258	172
	6 + 5							238	143	324	229	409	314	495	400		284	189
	6 + 6							221	118	307	203	392	289	478	374		310	206
GNP 800S	3 + 2	193	124	259	191	392	324										208	140
	3 + 3	165	83	232	149	365	282	498	415								250	168
	4 + 3	137	41	203	107	336	240	469	373								292	196
	4 + 4			176	66	309	199	442	237	575	465	708	598				333	223
	5 + 4					280	157	413	290	546	423	679	556				375	251
	5 + 5					253	115	386	248	519	381	652	514	785	647		417	279
	6 + 5							358	207	491	340	624	473	757	606		458	307
	6 + 6							330	165	463	298	596	431	729	564		500	335
GNP 1280S	3 + 2	332	222	438	329	651	542										309	200
	3 + 3	292	161	398	267	611	480	824	693								371	240
	4 + 3	252	99	358	205	571	418	784	631								433	280
	4 + 4			318	143	531	356	744	569	957	782	1169	995				495	320
	5 + 4					491	295	704	507	917	720	1130	933				557	360
	5 + 5					451	233	664	446	877	658	1090	871	1302	1084		618	400
	6 + 5							624	384	837	597	1050	809	1263	1022		680	440
	6 + 6							584	322	797	535	1010	748	1223	960		742	480
GNP 1600S	3 + 2	390	285	52	418	789	684										380	275
	3 + 3	335	209	468	342	734	608	1000	874								456	330
	4 + 3	280	133	413	266	679	532	945	798								532	385
	4 + 4			358	190	624	456	890	722	1156	988	1422	1254				608	440
	5 + 4					569	380	835	646	1101	912	1367	1178				684	495
	5 + 5					514	304	780	570	1046	836	1312	1102	1578	1368		760	550
	6 + 5							725	494	991	760	1257	1026	1523	1292		836	605
	6 + 6							670	418	936	684	1202	950	1468	1216		912	660
GNP 2300S	3 + 2	552	409	744	600	1129	985										554	410
	3 + 3	470	297	662	489	1047	874	1432	1259								665	492
	4 + 3	388	187	580	379	964	764	1349	1149								775	575
	4 + 4			498	268	883	653	1267	1037	1652	1422	2037	1807				886	656
	5 + 4					800	542	1185	926	1569	1311	1954	1696				998	739
	5 + 5					718	431	1103	816	1488	1201	1872	1586	2257	1970		1108	821
	6 + 5							1021	705	1408	1090	1791	1474	2176	1859		1219	903
	6 + 6							939	594	1323	979	1708	1363	2093	1748		1330	985
GNP 2500S	3 + 2	903	675	1195	968	1779	1552										787	560
	3 + 3	790	519	1083	811	1667	1396	2252	1981								943	672
	4 + 3	679	361	972	654	1556	1238	2141	1823								1101	783
	4 + 4			860	497	1444	1081	2029	1666	2614	2252	3199	2836				1258	895
	5 + 4					1332	923	1917	1509	2502	2094	3087	2678				1416	1007
	5 + 5					1220	767	1806	1352	2390	1937	2974	2521	3560	3107		1572	1119
	6 + 5							1693	1194	2278	1779	2862	2364	3448	2949		1730	1231
	6 + 6							1582	1037	2167	1623	2751	2207	3336	2792		1887	1342

DECLARACIÓN DE CONFORMIDAD CE

GENEBRE, S.A.

Av. Juan Carlos I, 46-48 – EDIFICIO GENE BRE
08908 L'HOSPITALET DE LLOBREGAT (BCN)

DECLARA bajo su única responsabilidad, que el producto suministrado:

Actuador Neumático de la serie 5800, tipo GNP

es conforme con los Requisitos Esenciales de Seguridad establecidos en el Anexo II de la Directiva 94/9/CE.

Para el cumplimiento de los requisitos, el producto es conforme con las normas:

- EN 13463-1: 2009
- EN 13463-5: 2011
- EN 983
- ISO 5211

El modelo dispone de un EXPEDIENTE TÉCNICO EN CUSTODIA nº LOM 08ATEX0037 / 01, y ha sido fabricado en:

GENEBRE, S.A.

Av. Juan Carlos I, 46-48 – EDIFICIO GENE BRE
08908 L'HOSPITALET DE LLOBREGAT (BCN)

Lo que le autoriza a colocar sobre el producto el marcado legal:

CE  II 2 GD – c T5 / T100°C

Fecha: 15 de Abril de 2011

Firma:  A. Martinez Romay

Director de Producto, División Industrial

“CE” DECLARATION OF CONFORMITY

GENEBRE, S.A.

Av. Juan Carlos I, 46-48 – EDIFICIO GENE BRE
08908 L'HOSPITALET DE LLOBREGAT (BCN)

DECLARES under its own responsibility that the supplied product:

Pneumatic Actuator 5800 series, GNP type

Is in accordance with the Essential Safety Requirements established in Annex II of the 94/9/CE Directive.

For the fulfillment of the requirements, the product is according to the standards:

- EN 13463-1: 2009
- EN 13463-5: 2011
- EN 983
- ISO 5211

Technical Custody File nº LOM 08ATEX0037 / 01.

The product has been manufactured in

GENEBRE, S.A.

Av. Juan Carlos I, 46-48 – EDIFICIO GENE BRE
08908 L'HOSPITALET DE LLOBREGAT (BCN)

who has the authorization to mark the product as following:

CE  II 2 GD – c T5 / T100°C



Date: April 15th, 2011

Sign:  A. Martinez Romay

Product Manager, Industrial Division