

ARTICULO: 2250

Mirilla de Turbulencia extremos Bridados.

Flanged ends Sight Glass.

Características

1. Mirilla de Turbulencia.
2. Extremos bridados según DIN 2501 PN 16.
3. Longitud entre caras según DIN 3202 F1.
4. Construcción en Acero Inox. 1.4408 (CF8M).
5. Presión de trabajo máxima 16 bar.
6. Cristal Sodocálcico Templado (DIN 8902).
7. Temperatura normal de trabajo: 130 °C.
Máxima temperatura (corto periodo): 160°C.
Choque térmico (DIN 52323): 120°C.

Features

1. Sight Glass.
2. Flanges ends according to DIN 2501 PN 16.
3. Face to Face according to DIN 3202 F1.
4. Made of Stainless Steel 1.4408 (CF8M).
5. Max. Working pressure 16 bar.
6. Tempered Soda-Lime glass (DIN 8902).
7. Normal Working temperature: 130 °C.
Maximum Temperature (short-term): 160°C.
Thermal Shock (DIN 52323): 120°C.

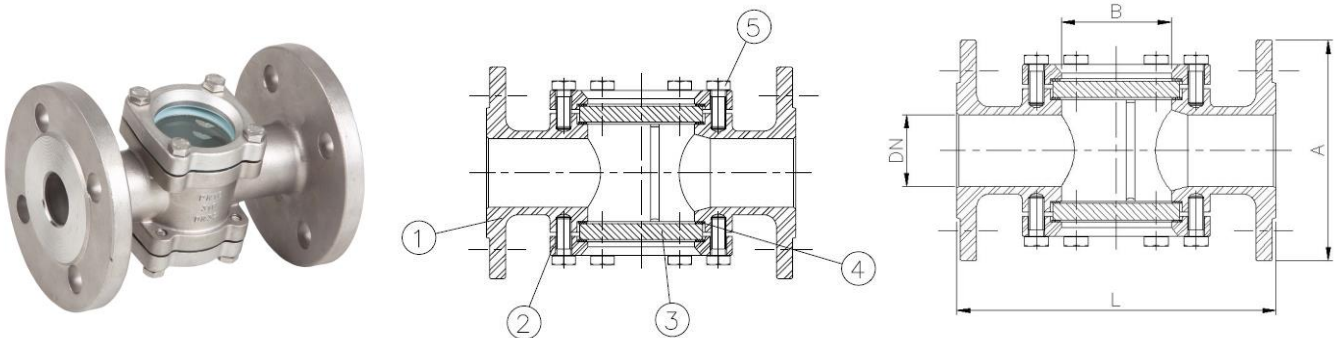

Nº	Denominación / Name	Material	Acabado Superficial / Surface Treatment	Ref.
1	Cuerpo / Body	Acero Inox. / Stainless Steel 1.4408	Granallado / Shot Blasting	-----
2	Tapa / Cover	Acero Inox. / Stainless Steel 1.4408	Granallado / Shot Blasting	-----
3*	Cristal / Glass	Vidrio Sodocálcico Templado / Tempered Soda-Lime Glass	-----	C2250
4*	Junta / Gasket	PTFE	-----	J2250
5	Tornillo / Bolt	Acero Inox. / Stainless Steel AISI 304	-----	-----

* Piezas de recambio disponibles / Available spare parts

DIMENSIONES GENERALES / GENERAL DIMENSIONS

Ref	Medida / Size	PN	Dimensiones / Dimensions (mm)				Cristal / Glass	Peso / Weight (Kg)
			DN	L	A	B		
2250 04	1/2"	16	15	130	95	40	Ø 50 x 8	2.250
2250 05	3/4"	16	20	150	105	40	Ø 50 x 8	2.800
2250 06	1"	16	25	160	115	50	Ø 63 x 10	3.650
2250 07	1 1/4"	16	32	180	140	50	Ø 63 x 10	5.750
2250 08	1 1/2"	16	40	200	150	65	Ø 80 x 12	8.300
2250 09	2"	16	50	230	165	65	Ø 80 x 12	9.800
2250 10	2 1/2"	16	65	290	185	100	Ø 115 x 15	13.700
2250 11	3"	16	80	310	200	100	Ø 115 x 15	16.650
2250 12	4"	16	100	350	220	125	Ø 145 x 15	23.800

CURVA PRESION TEMPERATURA / PRESSURE TEMPERATURE RATING

